

[www.fishman.com](http://www.fishman.com)

***FISHMAN***

**USER GUIDE  
INK BODY ONBOARD PREAMP**

# INK Body Quick Start

---

- 1. Set the controls** • Turn **volume**, **body** and **notch** down and set the **bass**, **middle**, **treble** and **brilliance** controls to center as shown.
- 2. Plug in** • Connect INK Body to an amplifier or PA with a ¼-inch instrument cable. The battery light will flash once quickly to indicate it has switched on.
- 3. Tune up** • Press and hold the right side of the tuner display to activate the onboard chromatic tuner.
- 4. Turn up** • Raise the **volume** and adjust the **bass**, **middle**, **treble** and **brilliance** controls to your liking.
- 5. Mix in the body sensor** • Raise the **body** control to mix in the onboard body sensor.

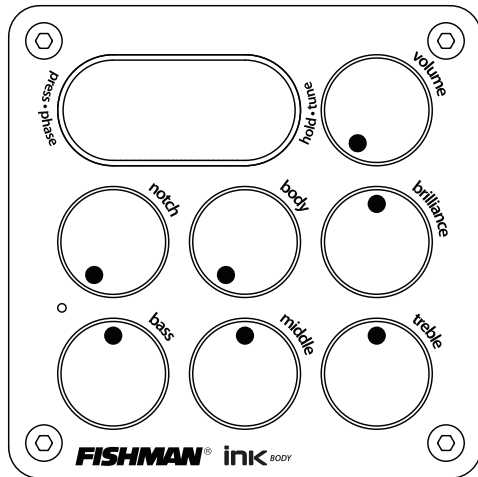

# INK Body Controls

---

**Volume** • For the cleanest signal, set the **volume** knob as high as possible, without causing distortion or feedback.

**Bass** • Boost here to add depth and weight to the sound of the guitar.

**Middle** • Turn the **middle** knob all the way left for a smooth “scooped out” tone at high volume levels. Raise the **middle** knob to the right of center to add midrange “bite” to the sound.

**Treble** • Boost to cut through the mix. Cut to mellow and subdue the sound.

**Brilliance** • This control can add shimmer and sparkle to your sound. It zeros in on crisp high frequency tones, the realm of harmonics and acoustic string sound. Lower the **brilliance** control to reduce finger noise and fret buzz.

**Notch** • Tune the **notch** filter to remove low-end feedback. Raise the **volume** until feedback occurs, then slowly turn the **notch** to the right until the feedback is eliminated.

**Phase** • Press the left side of the tuner display to toggle phase. Use the **phase** switch to improve bass response at low volume and suppress feedback at high volume.

**Body** • A body sensor is mounted under the bridge to enhance the natural resonance of the instrument. Turn this control up to blend the body sensor in with the pickup signal. At high volume levels, mix in less body to prevent feedback.

**Tuner** • Press and hold the right side of the tuner display to activate the onboard tuner; press once to turn it off. This digital chromatic tuner accommodates all standard and alternate tunings and mutes the output when engaged. It is calibrated to A = 440 Hz and can be activated without an instrument cable connected. To conserve battery life, the tuner will turn itself off after three minutes of inactivity.

**Battery** • When it is time to change the battery, a low battery indicator will light. To conserve power, unplug the instrument and turn off the tuner when not in use. Typical 9V alkaline battery life is approximately 80 hours (with tuner off).

On certain models, the low battery lights to indicate it is time to recharge the internal battery. Connect a micro USB cable and 5VDC, 500mA power source to the INK output box until the status LED indicates full charge.

**USB Output Jack** • If equipped, provides a USB 2.0-compliant digital audio output for direct connection to a computer. All preamp controls continue to operate as described and a battery is required when using this output.

# Sample EQ Settings

---

## Fingerstyle

This will add fullness to the bass and definition to the treble.

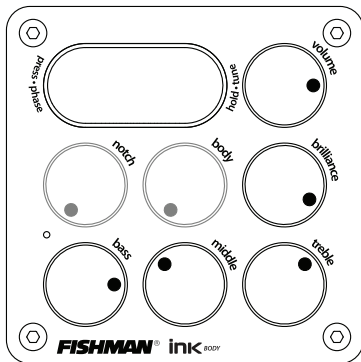

## “Scooped” Mid

This setting emphasizes extreme bass and treble

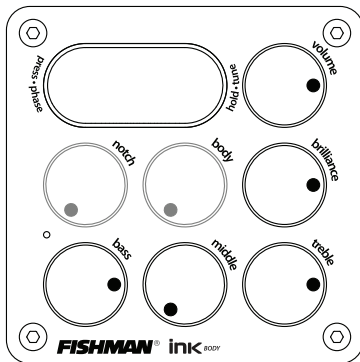

---

## Strummer

A good setting for strumming chords.

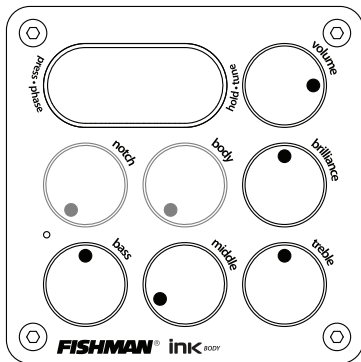

## Cut Through the Mix

When you need to be heard through a loud band.

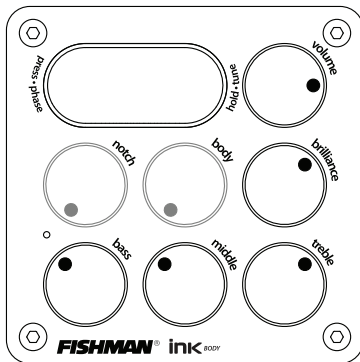

***FISHMAN***

[www.fishman.com](http://www.fishman.com)